

STRAIN GAUGE MEASUREMENT

Temperature compensation for leadwires in Quarter bridge

For strain gauge measurement, the Wheatstone bridge circuit is used to convert resistance change of the strain gauge into voltage output. The simplest bridge method is a quarter bridge, where one arm is composed of the strain gauge while the other three arms are composed of fixed resistors in the instrument. A 2-wire leadwire may be used for connecting the strain gauge to the instrument. However, if the temperature of the leadwire changes, thermal output of the bridge is caused even if there is no change in actual strain. For this reason, the quarter bridge 2-wire method should be used only when temperature change is not expected during the measurement or for a dynamic measurement in which the thermal output can be disregarded. A quarter bridge 3-wire method is available as a mean to eliminate the thermal output of the leadwire, when a 3-wire leadwire is used for connection of the strain gauge. In this method, the influence of resistance change of the leadwire caused by temperature change is cancelled. In addition, the effect of the leadwire on gauge factor is half as large as that of the quarter bridge 2-wire method. The quarter bridge 3-wire method is recommended over the 2-wire method, especially when temperature change is expected during the measurement and/or comparatively long leadwires are used. Other bridge methods including half bridge and full bridge are also available. Refer to p.17~20 for details.

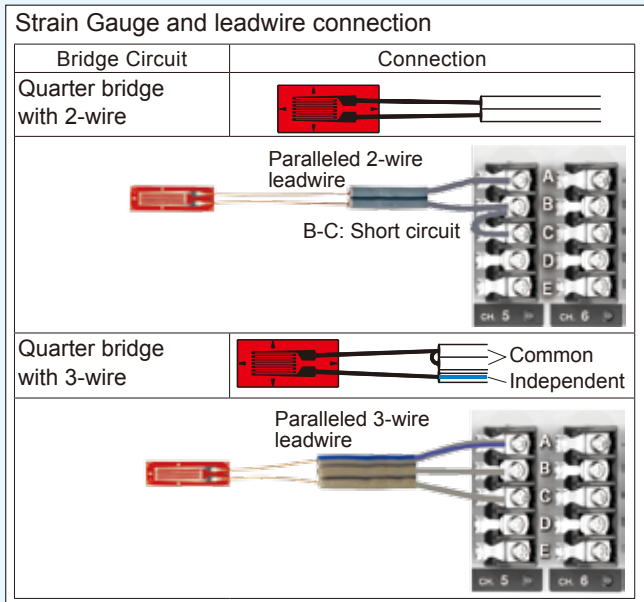

Thermal output caused by temperature change

In a quarter bridge 2-wire method, changes in leadwire temperature cause changes in the leadwire resistance, which result in thermal output. Use the equation below to compensate for this thermal output.

$$\text{Leadwire thermal output } \varepsilon L = \frac{r \cdot L \cdot \alpha \cdot \Delta T}{K \cdot (R + r \cdot L)}$$

where

- εL : Leadwire thermal output
- K : Gauge factor indicated on the strain gauge package
- α : Thermal coefficient of resistance of leadwire ($3.9 \times 10^{-3}/^{\circ}\text{C}$ for copper)
- r : Total resistance of leadwire per 1 meter (Ω/m)
- L : Leadwire length (m)
- ΔT : Temperature change of leadwire ($^{\circ}\text{C}$)

Note)

- Compensation is possible on condition that the temperature change is uniform for whole length of the leadwire.
- In a quarter bridge 3-wire method, compensation is not necessary because the influence of change in leadwire resistance caused by temperature change is cancelled.
- Also our 1-Gauge 4-Wire Strain measurement method does not require above correction because it is not influenced at all by the leadwire resistance. Refer to following page for details.

Gauge Factor (Gauge sensitivity) correction for leadwire connection

The leadwire resistance between the strain gauge and strainmeter noticeably lowers the gauge factor. Calculation for the correction is required depending on the measurement method and on the leadwire type and length.

Quarter Bridge with 2-wire	Quarter Bridge with 3-wire
Correction coefficient of leadwire : A $A = \frac{R}{R + rL}$	Correction coefficient of leadwire : A $A = \frac{R}{R + \frac{rL}{2}}$
Corrected Gauge Factor : K_0 $K_0 = \frac{R}{R + rL} \cdot K = A \cdot K$	Corrected Gauge Factor : K_0 $K_0 = \frac{R}{R + \frac{rL}{2}} \cdot K = A \cdot K$
where R : Nominal gauge resistance in Ω r : Total resistance per meter of leadwire (Ω/m) K : Gauge Factor shown on package L : Length of leadwire in meter	

Total resistance per meter of typical TML pre-attached leadwire

In strain gauge, the leadwire resistance produces a deterioration of gauge sensitivity and thermal drift. The leadwire should be as thick and as short as possible.

Twisted leadwire



Construction core/diameter	7/0.12	10/0.12	7/0.16	7/0.18	12/0.18	20/0.18
Cross section area of lead wire (mm^2)	0.08	0.11	0.14	0.18	0.3	0.5
Total resistance of leadwire per meter (Ω)	0.44	0.32	0.24	0.20	0.12	0.07

Single-core leadwire

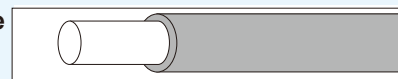

Construction	Polyimide wire (0.14mm-dia.)	Polyimide wire (0.18mm-dia.)
Cross section area of leadwire	0.015 mm^2	0.025 mm^2
Total resistance of leadwire per meter	2.5 Ω	1.5 Ω

Setting the Gauge Factor to TML Data Loggers*

$$C_s = \frac{2.00}{K_0} \quad C_s : \text{Coefficient set} \quad K_0 : \text{Gauge Factor corrected with leadwire attached}$$

For the detail of Data Loggers, refer to page 97.